

Learning to Live with Solar Energy in Southern Spain – second revision September 2008.

Alan Cartwright

AlanC@code-a-text.co.uk

www.code-a-text.co.uk/LivingSpain.aspx

Learning to Live with Solar Energy in Southern Spain – second revision	
September 2008.	1
Preface	4
Acknowledgements	5
Introduction	6
The Basic Components	7
Power Generation	7
Wind Turbines	7
Solar Panels	7
Fuel-Powered Generators	8
Power Storage	8
Batteries	8
Battery Chargers	9
Power Supply	9
Direct Supply	9
Inverter	9
Generator	9
Efficiency and Temperature	9
Efficiency	10
Temperature	10
Appliances and Efficiency	10
Methods of Combining the Components in a Solar System	11
Low Power System	11
The High Power System	12
The Nautical System	13
The Battery Support System	13
The Hybrid System	14
Comments on Individual Components	14
Solar Panels	14
Panel Types	14
Panel Voltage	15
Panel Orientation	15
Seasonal Changes in Solar Radiation	16
Panel Shading	17
Panel Wiring	17
Panel Cleaning	18
Generators	18
Manual or Electric Start	18
Open or Silenced	18
Size	18
Fuel	19
Location	19
Generators and Appliances	20
Voltage Creep	20
Batteries	20
Battery Size - Voltage	20
Battery Size - Capacity	21
Battery Configuration	21
Battery Connections	22
Battery Charging	23
Equalisation Charging	24
Battery Maintenance	24
Battery Management	24

Solar Regulators.....	25
Inverters	26
Battery Chargers.	27
Combined Battery Chargers and Inverters.....	27
Will your appliances work with your system?	28
Running Domestic Appliances Efficiently	29
Selecting Energy Efficient Items	30
Lights	30
Domestic Goods.....	30
One Pot (slow) Cookers	30
Computers	31
Appliances on Stand-by	31
Using Timers to cut Consumption	31
The Inverter.....	32
Conclusions.....	33
12 volt Systems	33
A Basic 24-volt System	33
An Enhanced 24-volt System.....	34
Could we reduce our consumption further?.....	34
How do we feel now?	35

Preface

In the summer of 2005 we bought a partly built *cortijo* in Southern Spain. Although the property had drinking water there was no prospect of a connection to the electricity grid. Mostly, we used local craftsmen to finish the building but after some thought we decided to use an English-speaking company for the solar installation. We got some general quotes and then selected “Remote Energy” an English registered company trading in Spain, which is based in northeast Almeria.

The Remote Energy web site was well presented and in our discussions all seemed well. However, there were problems from the day the system was installed in June 2006. After a few weeks it became apparent that the system was not functioning as expected. From the outset the Elecsol batteries did not seem to be functioning properly. Then the Victron inverter/battery charger failed creating endless problems.

After a few months we involved a Spanish neighbour who had been a solar engineer. Under his guidance we started to change the system. The panels were moved and connected with cable of the correct thickness. The battery racking (which prevented the batteries being serviced) was removed. The solar charger and the Inverter/ Battery charger were replaced. Finally, given that neither the installer nor the manufacturer of the batteries (Elecsol) was prepared to take responsibility we replaced the batteries with a group of lorry batteries. The latter was a calculated risk. They were much cheaper, dramatically outperformed the Elecsol batteries but would they last?

Now we had a functioning system. The system had been redesigned and apart from the panels, their mountings and some battery wiring nothing remained of that installed by Remote Energy. Concurrently, we worked on reducing our energy consumption and this along with the new system provided a basic functioning solar system, described later as a Basic 24-volt system. This system was heavily dependent on the generator and required considerable “hands-on” activity to get the best performance. However, it worked!

The calculated risk with the batteries did not work to our advantage and (soon after their guarantee expired) they began to fail. It was time to get proper deep cycle solar batteries. I was in contact with the Energy Development Co-operative (www.solar-wind.co.uk) who had contacted me with offers of advice after reading an earlier version of this article. After extensive exchange of e-mails (thrashing out the design) we decided upon a major upgrade to the system. We added three more panels, changed the solar controllers to the latest type and added a large deep cycle battery. We also changed the basic installation, adding isolation switches and buss bars, which had not been fitted in the earlier installation. They fabricated the components, which were sent from UK, and I upgraded the system.

Finally, we had a system that worked. In the six months since it has been installed we have hardly used the generator at all (5%) of the power consumed now comes from the generator and our consumption of gas (the generator runs on gas) has fallen dramatically. Last year we used 15, 35kg bottles of gas between April and the end of September. This year we are still on our first five. Further more, the system hardly needs watching at all.

Before we installed our system, I read general articles on the web and talked to a few people about their systems and had come to the conclusions that they were straightforward. I could not have been more wrong. Indeed the Spanish engineer and

Remote Energy approach solar energy with totally different philosophies and these were reflected in their installations. As the problems began, I read more and talked to others about their experiences. Most of the people I spoke to had problems with their systems, which did not meet their needs. A longing for a mains connection was common.

The whole experience has not just been costly but also very stressful. For much of the first year we were living with the generator running, to the annoyance of neighbours. There was also the perpetual anticipation that the system would shut down if not monitored. Then there were the hours spent, reading and on the phone, trying to find information which was in a form that I could understand. Without the understanding it was very easy for the “experts” to dismiss our concerns. Now most of those anxieties are in the past and I am writing this article in the hope that others can benefit from our experience and make choices that are in their interest rather than those who install their system.

I do not claim any expertise but I have learnt from experience. I completed an electrical apprenticeship some 40 years ago, and that has helped, but since then I have not worked in that field, spending most of my working life in hospitals and universities practising, teaching and researching psychotherapy. I retired 10 years ago.

Some readers will find this article simplistic, others over-complex. This is inevitable and reflects my attempts to communicate my understanding to those without any previous experience. The themes discussed here reflect my own experiences and do not seek to totally cover the field.

There are bound to be omissions and errors and I would welcome any comments and corrections.

This is the second revision of the original article. The first two versions focussed on our experience of installing and setting up the original system. This focuses more on the knowledge gained in the process.

On the web site you will also find a photo essay describing the building of our cortijo. Information about current weather in Canjajar, the Iberian Peninsular and Western Europe along with software I have written to facilitate learning Spanish verbs.
www.code-a-text.co.uk/LivingSpain.aspx

Acknowledgements

I would like to thank Phil Tilson - Moderator of the Fincas in Spain Web Group (<http://groups.yahoo.com/group/fincasinspain/>) - who volunteered to proof-read the original article and helped me to correct errors in punctuation and the use of scientific units. I would also like to thank Graham Robey of the Energy Development Co-operative who finally helped me to sort of the system.

Introduction

In theory you can install a system that will provide free electricity anywhere in Southern Spain but the cost of that installation will depend upon your power needs and location. From a power point of view the ideal location is one that faces south with continuous sun from morning to evening. Even with this aspect, the cost of the installation is proportional to the amount of electricity required.

Our land faces north and we cannot get a full day's sunshine, even in summer – which can be a blessing. We do get some winds, but these are “mountain winds” which blow up the valley during the heat of the summer's day. In winter and at night we are invariably calm – so a wind generator is not viable.

Our consumption was probably high for those living in a house supplied by solar energy. We designed our house to have a traditional exterior and a modern interior. We wanted a gas fridge-freezer but could not find one that was compatible with our lifestyle so we chose an electric model, which is also more convenient than a gas model. Also my main interest was focused on the weather and I ran a weather system with a computer connected to the Internet 24 hours a day.

When we started using solar energy our basic consumption using these items and others such as lights, but excluding heavy use things like washing machines, air conditioning, power tools etc was about 5000Wh (5 kWh) a day. Watt-hours are the units used to measure energy, or the quantity of electricity consumed – on a normal electricity bill, for example. At the winter solstice our six 85 watt panels only supplied 600Wh. Thus to be comfortable in winter we would need 60 panels! However, in summer, when the sun is above the mountain most of the day, we can nearly supply all our basic needs from the six panels. To cover our winter needs is not affordable using solar panels alone, so we needed a compromise system. In practice this means using a generator for part of the time.

In choosing a solar system we have come to realise that there are various choices that need to be made and these were not discussed with us – I am sure all solar engineers will tell you they would discuss these issues with their clients but I have my doubts as the installers that I have encountered tend to have a perspective into which they fit the client.

These issues broadly fall into three areas.

1. What are your wishes for power? You can choose to run a full system off solar power, but at a cost.
2. How far are you prepared to be “hands-on” with your system? A hands-off system would be seamless, just like using mains electricity. This is what we anticipated but it never materialised. If it had functioned as we expected I now know that the running costs would have been impossibly high. “Hands-on” implies monitoring your power usage and switching to the most efficient supply source at any time.
3. How much security do you need in your supply? Can you tolerate it not working for days or weeks?

The article is divided into various sections

1. A description of the basic components found in a solar system; how you generate power, how you store it and how you distribute it to appliances.
2. A discussion of the basic issues that affect the efficiency of solar systems. In an efficient system all the power you generate would be available for use; in practice it is much less.
3. A description of the different ways solar systems can be organised. Basically, there is no such thing as a standard installation.
4. Comments on individual components – e.g. How do you choose a generator?
5. Will your appliances work? Think twice before you invest in that expensive, highly efficient washing machine.
6. Running domestic appliances efficiently – how we managed to cut consumption.
7. Conclusions

The Basic Components

The basic components of an off grid power system can be divided into three major groups concerned with power generation, storage and supply.

Power Generation

There are three main methods for generating power in an off grid system: wind generators, solar panels and fuel powered generators.

Wind Turbines

Looking at the specifications of wind turbines, they seem to me to be a cost-effective method of generating power. However, you need wind and we have very little. Thus I have no experience with these and will not consider them further. Though there are a number of solar installations in our area none, to my knowledge, includes a wind turbine.

Solar Panels

These are the main method for generating power in off-grid systems in southern Spain. These panels are different from those from those used to heat water. Solar electricity panels consist of arrays of photovoltaic cells, each generating a small voltage when exposed to sunlight. These are connected together in the form of a panel. Those used for domestic solar systems are normally rated at 12 or 24 volts, though the maximum voltage they supply can be higher. The panels used in solar electricity systems commonly have a power rating between 40 and 200 watts. The higher the power rating, the more cells required and the larger the panel. Panels themselves can be combined together.

Connecting **two 12-volt, 85 watt, panels in series (positive to negative poles)** increases the **voltage** of the system. Thus two 12-volt panels connected in series create a 24-volt system capable of delivering 170 watts.

Connecting **two in parallel** (positive to positive) increases the **power** that can be delivered without changing the voltage.

Normally, 24-volt systems, based upon 12-volt 85-watt panels are grouped into three pairs of series connected panels, which are joined by parallel connections. In theory these panels can produce 510 watts at 24-volts, in practice 400-watts is more likely. The output is always direct current (DC) and this is not suitable for many applications (see comments below). In many systems the solar panels are used to charge batteries. Once installed, solar panels supply free power and do not require maintenance.

Fuel-Powered Generators

The fuel generator consists of an engine which turns an alternator that produces an alternating current (AC), usually at 220 volts. Petrol, diesel, bio fuels or even gas can power the engine. Because the generator supplies AC, provided it has a stable output, it can supply power directly to the house, and be used to charge batteries. The generator uses fuel and therefore has a running cost. To be reliable, it also requires regular maintenance – much more frequently than a car!

Power Storage

Batteries

Although the sun shines most days it never shines at night, so electricity developed during the day needs to be stored. Similarly if a generator is supplying power it is probable that you will want to switch it off during the night. So, some of the power generated has to be used to charge batteries, which can then be used to supply power during the night. In some systems, the power generated is only used to charge the batteries from which all the household power is taken. Power is always taken from batteries as direct current (DC). This can be directly connected to the house in a low-voltage system or converted to alternating current (AC) if the house has a high-voltage (or ‘normal’ mains) system.

Strictly speaking, a *battery* is made up of a collection of *cells*, each of which generates approximately 2 volts. The batteries (or cells) used in solar systems commonly come in 12-volt or 2-volt units. These are then connected together (in the same manner as solar panels) to give the required voltage (normally 12 or 24 volts). Confusingly a group of battery units connected together is referred to in the singular as a battery.

Each battery has a rating that describes its ability to supply power. So an individual unit, which is rated at 200 ampere-hours (Ah), could theoretically supply 20 amps for ten hours. Batteries can be connected in the same way as panels – as described earlier. By connecting batteries in parallel the capacity of the system can be increased.

The batteries used in solar systems differ from those used in a car. The car “starter battery” is designed to provide a very high current (to turn over the engine) for a short period of time. Conversely the batteries used in solar systems are designed to supply a much lower current over a longer period of time. There are two types of solar batteries, often referred to as “leisure” and “deep cycle” batteries.

Traditionally, the batteries used in solar systems have been made up of a group of 2v cells connected in series to create the working voltage of either 12 or 24 volts. These “deep cycle batteries” can have very high capacities, such as 1200 Ah and seem to be the most efficient and reliable.

A variation on these is the “leisure battery” in which the cells are grouped into units to create a single 12-volt battery. These are rarely larger than 250 Ah each, which is fortunate because a battery of that capacity can weigh over 60 kilograms.

Although a small solar system can be run from large starter batteries (for instance 180Ah lorry batteries), these will quickly fail if they are regularly discharged. Leisure batteries will have a longer life under such conditions but it is only deep cycle batteries that will withstand the demands of a large solar system in regular use.

Battery Chargers

Batteries are expensive and the way they are charged can dramatically alter their effective life. Both overcharging and undercharging can be damaging and so “intelligent chargers” have been developed to ensure that the batteries are charged most efficiently. Although you can charge solar batteries using a normal car charger it is unlikely they will be fully charged and they risk being damaged. If the generator is being used to charge the batteries then there will be a battery charger. Between the solar panel and the battery is a solar regulator, which prevents overcharging. More about these will follow.

Power Supply

Direct Supply

In some situations the power is taken directly into the house from the batteries or from the solar regulator. These are the DC or low voltage systems.

Inverter

Most houses use AC for their power supplies. Before power from batteries can be used in a high voltage system it has to be converted from DC to AC. This is achieved by an inverter, which converts the DC (typically at 12 volts or 24 volts) to AC (usually between 220 volts and 230 volts). Inverters can be manufactured to supply 6kW or more power. However, as the power supplied increases, so does the required battery size. It is rare to find an inverter that supplies more than 1500 watts working on a 12-volt battery; one reason being that the size of the cables required to carry the current becomes too great.

Inverters are categorised by the type of waveform they produce. In Europe the mains AC supply changes between positive and negative 50 times every second. This is called the frequency of the supply. In a perfect supply this change over is perfectly smooth and takes the form of a sine wave. The best inverters can supply a “pure sine wave” and will run any appliance that can run on the mains. Less smooth, but also much cheaper, is a modified sine wave, which will run most appliances. An inverter with a square waveform output should be avoided because many appliances will not work with the output they generate.

Generator

The generator can function as a power supply into the house. In some systems the generator is the main power supply and the solar system and batteries are secondary. In others the generator is only used occasionally. Most generators produce something close to a sine wave output.

Efficiency and Temperature

Before describing the different types of system it is worth mentioning the important issues of efficiency and temperature.

Efficiency

In the current context efficiency refers to the fact that whenever you convert energy from one form to another you lose some energy in the process. For instance the energy you get out of a generator (in the form of electricity) is always less than the energy that goes into the machine in the form of fuel. The measure of energy used is usually the watt-hour (Wh), which describes the number of watts (volts x amps) being supplied multiplied by the number of hours for which they are supplied. This is slightly misleading because when dealing with alternating current the calculations are slightly more complex. But for illustrative purposes it serves. Watt-hours are the units in which mains electricity bills are calculated. 1 kilowatt-hour (kWh) is 1000 watt-hours, the energy used by an appliance, connected to a 220-volt AC supply, using roughly 4 amps over 1 hour, or 2 amps over 2 hours. Theoretically, for a 12-volt battery to supply this power it would be required to supply 80 amps whilst a 24-volt system would need to supply 40 amps. However, because there are inefficiencies in the system the actual demands on the batteries will be greater.

There is a degree of inefficiency in all systems that generate electricity. In a recent booklet, aimed at helping consumers understand the need for efficient use of mains electricity, the Spanish government stated that for every kW of power delivered to a house the equivalent of 3 kW of fossil fuel had to be consumed.

Currently, solar panels only manage to convert 15% of the energy received from the sun. However, in a solar system you often transform the energy from the panels on many occasions. The more often you transform the energy the less efficient your system. Many solar chargers provide a figure for the amount of energy received from the panels. For instance, take a set of panels that has supplied 2000Wh over a day; unfortunately because of losses due to inefficiency that is not the power available to run appliances. A general figure of 85% efficiency can be used as a guideline for most components. For instance the power available from the batteries will be less by 15% (i.e. 1700 Wh) and if this is being passed through an inverter before going to appliances then only 85% of that 1700 Wh will be available. i.e. 1445 Wh. So the initial 2000 Wh translates into less than 1500 Wh available to run appliances (about 75% efficiency).

In practice this appears a little optimistic. I have measured our system twice (over long periods during the summer) with different configurations of panels, batteries and consumption and on each occasion found the efficiency of the system to be a little under 60%. In other words we need 1 kWh of solar power for each 600 Wh that we consume.

Temperature

Most items in solar systems are affected by temperature. Solar panels are most efficient in freezing conditions and the capacity of batteries to supply power falls off with rising temperature. At least one make of inverter found in solar installations has a rating of 3 kW at 20 °C but this falls to 2 kW at 40 °C. Elecsol, a manufacturer of carbon fibre-based lead acid batteries, offers a 5-year guarantee in Britain but not in Spain because of the effects of temperature on the performance of their batteries. During the summer, temperatures above 35 °C are common in southern Spain, so our systems are always least efficient when there is most sun!

Appliances and Efficiency

It is worth taking the points regarding efficiency a little further. Take a washing machine running from the inverter. If there were not sufficient solar power the

batteries would have to be charged up from the generator. As the power moves through each component in the system it is reduced by 15%. So if we start with a 100 units of fuel (in our case gas) we then lose 15% through the generator, 15% through the battery charger, 15% through the batteries and 15% through the inverter. Thus we only have 52% of the original power left to supply the washing machine. To deliver the equivalent of 100 units of fuel to the washing machine requires a supply of 200 units. To run the appliance from the generator would require a little fewer than 120 units. Obviously these calculations are based on the assumption that there is insufficient solar power. If you have the available power then directly running the washer from the inverter is more efficient. (See comments later about washing machines.)

In theory a gas refrigerator is much more efficient than an electric powered model run from the inverter, as it takes its power directly from the gas supply. However, the process, which uses heat to produce cold, is much less efficient in gas fridges than in electric fridges; they also have the disadvantage of generating more heat because they use an open flame as part of the cooling process. So the difference in total power used may not be as great as it first seems. However, if you use an electric fridge-freezer, it is likely to consume more power in a day than any other item, unless you use one of the latest A+ rated appliances, which claim to use less than 1 kWh per day.

Methods of Combining the Components in a Solar System

When I first started exploring solar systems I assumed there was just one way of going about putting these systems together. I was vaguely aware that there were differences of opinion but only in the sense that some engineers would make disparaging remarks about others' installations. Now I realise that there are at least five types of system being installed, each with its own philosophy. I refer to these as the Low Power System, The High Power System, The Battery Support System, The Nautical System and the Hybrid System. These are my ways of describing what I have encountered and to my knowledge these terms are not used elsewhere. The idea here is to present the basic structure of the system, in practice they tend to merge into one another.

Low Power System

The low power system is the type most commonly found in the Spanish owned *cortijos*, mainly used at weekends, in our valley. They consist of three components – solar panels, a battery regulator and battery. The battery supplies 12 volts DC and this is normally taken straight into the house, providing lighting using energy efficient bulbs.

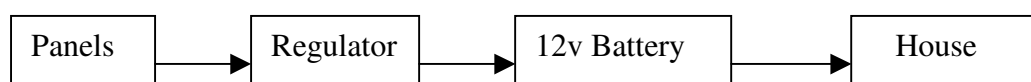

I had not given much thought to these systems until I realised that we knew a couple living virtually full-time in a house with a 12-volt system. He is a retired solar engineer. They seem live quite normal lives! When you think about it, it is not so surprising; anything that you can operate in a car can also be run from a 12 V solar

system. A small inverter, plugged into a DC socket, can supply power for things like Sky boxes, LCD televisions and portable computers. Items like washing machines can be run directly from a generator and all other requirements are supplied by gas.

The point about these systems is that they are comparatively inexpensive to install and, having fewer components, are the most efficient way of converting solar energy. If I were installing a system in a holiday home this is the route I would consider.

The High Power System

In its basic form the high power system is a variation on the low power system. However, instead of feeding the supply directly from the batteries into the house, an inverter is placed in the circuit so that the supply is now AC. Usually, in Spanish-installed systems, the inverter is quite small and the power is limited to about 600 watts. Items like washing machines can be run directly from a generator and all other requirements are supplied by gas.

If the power required is more than 1500 watts then there is a quantum leap forward in costs. To supply the greater power it is necessary to upgrade to a 24-volt solar system. This means twice as many panels and batteries. Again, items like washing machines can be run directly from a generator and all other requirements are supplied by gas.

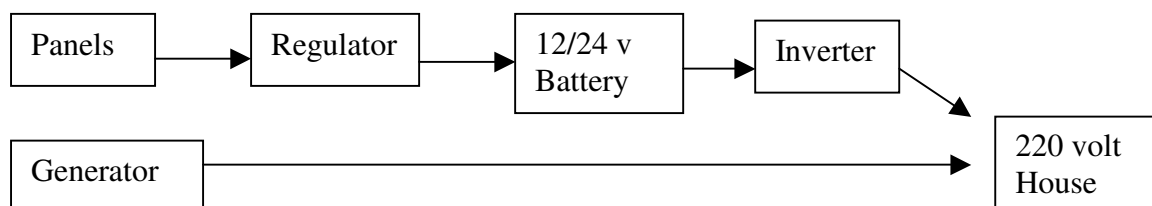

When the Spanish engineer came to look at our system, this was the approach he took. What fascinated me was that he was surprised that the house was not wired with two power circuits. Apparently one approach to these systems is to connect the solar supply to the lower capacity power circuit and the generator to the other. Whenever an appliance is plugged into the higher capacity circuit, a sensor detects its presence and starts the generator. I have not seen this working but it is an interesting approach. Another variation I have encountered is to use two inverters, one supplying lighting circuits and another power circuits.

The main point with the approach taken to this system is that you have to calculate your daily solar power needs, with a calculation for the number of days that need to be supplied without sun, and this determines the size of the system.

The Nautical System

I refer to this approach as the nautical system because it was developed for boats. The assumption is that the solar panels and the generator are seen as equal partners in the process of power generation. The battery charger and the inverter are often in a combined unit (CBCI – for short). All appliances are assumed to run from the inverter, which has to be large enough to supply all the appliances that may be working at the same time. When calculating the size of the battery it has to have the capacity to supply this inverter for a set period of time. When the generator is running, the internal system of the CBCI will switch the supply from the generator to the house whilst also charging the batteries. The inverter is disconnected. The total power rating of the CBCI limits the combined system, as will be described later. If a low battery switch is incorporated into the system, the generator can start automatically when the battery voltage goes below a set level. Thus in theory it should work seamlessly and, from the users' point of view, is like a normal house.

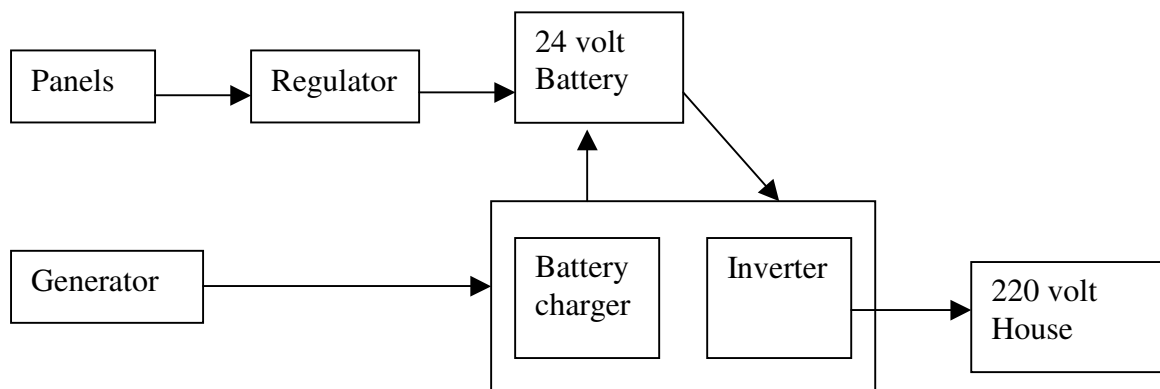

This was the system that we initially had installed. It was expensive, did not deliver its promise and eventually faltered on component failures.

The Battery Support System

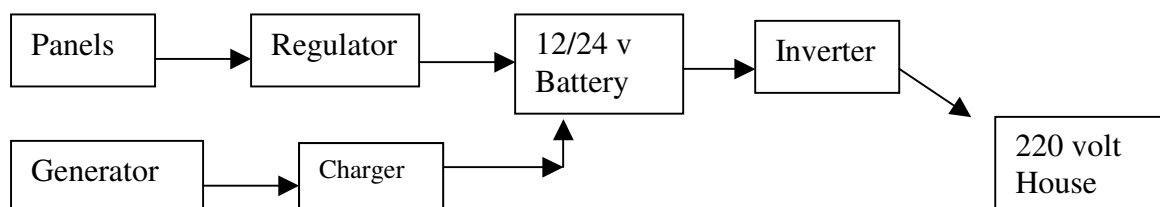

I saw this system installed by a Spanish company supplying a 2kW inverter. The generator is never connected to the household supply but only used to charge the batteries.

The Hybrid System

One of the things that most surprised me about the way the *high power* systems were installed was that they did not have any facilities for charging the batteries. I know of many of these installations, by different companies and none installs battery chargers. Indeed, when I asked the Spanish engineer for a reasonably priced battery charger, the battery charger he produced was a car battery charger for a garage. Eventually, I bought a pair (more of which later) from Britain over the Internet. Later one of my Spanish neighbours asked me to get one for him, at the recommendation of the Spanish engineer. We have now found the same items supplied in Spain but they are much more expensive.

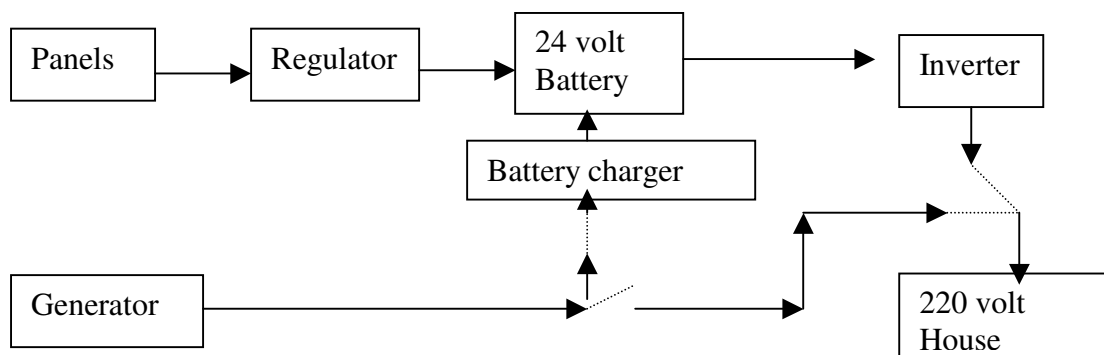

In our hybrid system there are two options one that mimics the nautical system but with more control over the way the system works. The other is like the battery support system. Manual switches determine how the system is configured.

In the first option, the main household supply is connected to both the inverter and the generator. When the power from the generator is switched to the house the inverter is disconnected. The battery charger can be switched on or off according to whether the battery requires charging. Whenever a high demand item is used (e.g. washing machine or irrigation pump) then the power is switched over to the generator. The generator is sufficiently powerful to be able to supply these items whilst charging the batteries. In the winter evenings, when there has not been sufficient sun, the generator is used to charge the batteries and provide the household supply. Thus we can maintain our relatively high load without too much inconvenience.

When we increased the size of our batteries and added new panels, we also added the option of running the generator in battery support mode. Since I installed this option, last February (2008), we have not had the generator connected directly to the house. If the batteries are showing stress on a heavy load the generator is switched on to provide them with additional charge

Comments on Individual Components

Solar Panels

Panel Types

There are three major types of panel monocrystalline, polycrystalline and amorphous. They are all based upon silicon semi-conductors but the way they are assembled differs. That the advantages and the disadvantages of the different types tend to cancel out and in terms of cost per watt of power produced they are fairly similar.

Panel Voltage

The panels used in domestic solar systems are usually rated as either 12 or 24 volt. Two 12-volt panels may be joined together to create the equivalent of a single 24-volt panel. However the important voltage is the maximum voltage supplied. Our original array consisted of 6, 12-volt, 85-watt Shell monocrystalline panels, each of these create a maximum voltage of 17.2 volts, or 34.4 volts in our 24-volt system. Plenty to charge a 24-volt battery where the maximum voltage required is around 28.6 volts.

I wanted to supplement this array with a 24-volt, 175-watt Kyocera polycrystalline panel and was told this was possible. However, I was disappointed with the performance. It was only when I was redesigning the system that it was pointed out to me that the new panel, though sold as a 24-volt panel had a maximum output of 23.6 volts. It would only charge a flat 24-volt battery!

In the end the solution was to create a stand-alone array of three of these panels in series, giving a maximum voltage of 70.8 volts. This was stepped down to the required voltage by a MPPT solar controller (see below).

The six 85-watt monocrystalline panels combine to provide up to 510 watts. The 3 175-watt polycrystalline panels combine to provide 525 watts. Thus if the two sets of panels were working equally we would expect the 85-watt array to provide 95% of the power of the 175-watt array. In fact they supply around 92%, a difference that could easily be accounted for using different controllers and different wiring.

Panel Orientation

The basic design of solar panels means that they generate most power when the sun's radiation strikes the surface at an angle of 90 degrees. At the winter solstice, in Southern Spain, this occurs if the panel is set at about 70 degrees from the horizontal at 2pm in the afternoon. However, in summer the panel should be set at 30 degrees because the sun is higher in the sky. Further, as the sun moves through an arc in the sky, the panels should ideally follow the sun – which is what happens in commercial installations. However, most domestic installations are fixed with the panels set at 70 degrees facing due south. In other words they are maximised to supply power during the winter. Does this make a difference? – yes it does.

I requested that our panels be mounted on a bracket that allows them to be moved both in the vertical and horizontal planes and Remote Energy did make a bracket for me. I can adjust the angle for the time of year and I can move them two or three times a day to maximise the power.

The effects are shown in the figure below. The readings were taken on the 27th May 2007. There is nothing significant about the date. I read the number of amps being produced by the panels at five different times of the day, changing the orientation of the panels on each occasion. The reading marked 'sun' was with panels facing the sun as far as I could judge. In fact the orientation corresponded to roughly East (10:00), South East (12 noon), South (14:00), South West (16:00) and West (18:00).

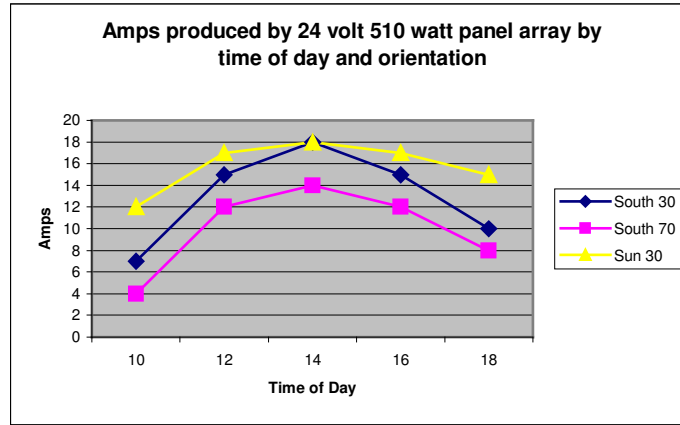

The first general point is the difference between the sun tracking readings and the 70° South readings. On average the fixed panels are producing 40% less power than the moving panels at 30°. The difference is much greater in the mornings and evenings.

The second point is that between 12 noon and 16:00 hours the difference between the sun panels and those at 30° south is small.

In early July I was moving the panels twice a day. Facing South East in the morning and changing to almost due West in the afternoon. This procedure is providing on average 3.4 kWh a day. Without these adjustments the panels were producing 2.5 kWh or 30% less power.

In the winter this is less effective because the panels are shielded from the sun until 11:30 and the sun's arc through the sky is much smaller. The most effective gains are in spring and autumn because in summer we have sufficient power.

If you have a static solar system, it is necessary to base your calculations for your power needs, and thus the number of panels, on the available solar supply in winter. The extra power in summer is lost. This would not be financially viable in our system where the available winter power is lower. In our original system (510-watt), by using the combination of generator and panels we were able to run most of the summer on the six panels alone (provided that they were moved), but in mid winter we were largely dependent on the generator. In our new system (1035-watt) generates sufficient power so we only move the panels to change their angle toward the sun in the winter.

Seasonal Changes in Solar Radiation

There are three ways in which the seasons influence the power gained from solar panels. First, solar radiation is most intense at the time of the summer solstice (mid June) and weakest at the winter solstice (mid December). Secondly, daylight hours are shorter and thirdly there are more overcast days.

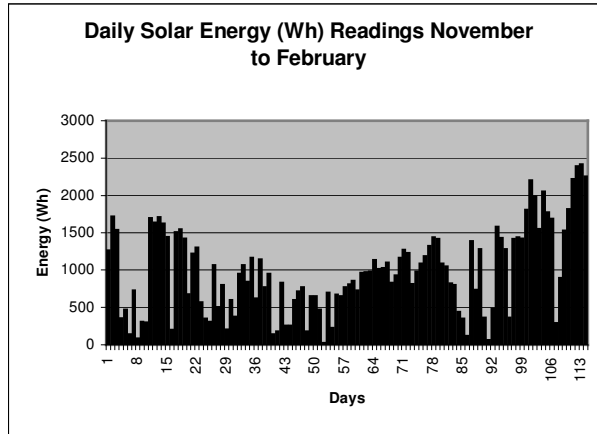

Figure 2

Figure 2 shows, the amount of solar power energy we got (from our 510-watt array) between November and February 2006. Two clear patterns emerge. Day 50 is the winter solstice and the amount of energy declines from the beginning of November till then and then starts to increase again. However, there are considerable variations within this trend. Unfortunately, there are blocks of good days and blocks of bad days. It is rarely the case that you get a good day followed by a bad day, followed by a good day. This means that in calculating the number of batteries needed you must to ask yourself, for how long do I want my system to work without a supply from panels or generator?

Panel Shading.

It is important that panels are fully exposed to sunlight and not shaded by other panels or trees. The effect of shading on power output varies with the type of panel but is always greater than one might expect. In our polycrystalline set 10% shading reduces the power output by 90%! In the monocrystalline set 10% shading reduces the power output by 40%.

Panel Wiring

Another important issue is the wiring from the panels. The resistance of the cable affects the current passing from the panels to the solar regulator. The smaller the cable the higher the resistance and the greater the distance the greater the power loss. For a 500-watt 24-volt system the following cable sizes are recommended to prevent less than a 5% voltage drop. (Source <http://www.solar-wind.co.uk/>)

Distance (metres)	Cable Thickness (mm)
3	2.5
10	6
30	25

For a 12-volt system the cable sizes should be doubled.

Our panels are mounted about 20 metres from the batteries and had been installed with 4 mm² cables. When these cables were replaced with 20 mm² cables the power reaching the batteries from the panels increased dramatically.

Recent advances in solar chargers have offered an alternative solution. Some of the new MPPT solar chargers allow the panels to be connected to create a higher voltage system. When we installed our three 24-volt 175-watt panels we connected them in series to create a 72-volt system, which allowed us to use 10mm cable. The solar charger then steps the voltage down to 24-volts.

Panel Cleaning

An issue, which should not be ignored, is the cleaning of the panels. In the hot dry summers there is a lot of dust, which will form a coating over the panels. My measurements suggest that in dusty weather even a week's dust can reduce the output from the panels by more than 10%.

Generators

The question most often asked about generators is – what type of fuel is best? However, there are other important issues as well.

Manual or Electric Start

This question is more important than one might immediately think. Obviously, if you want any form of automatic or remote starting then you must have an electric start model. Another issue is, who will start the machine? I have met several women who were anxious, because they did not have the strength to start the generator, which supplied the backup power.

Open or Silenced

This really is a misnomer because the choice is between loud and less loud. If the generator is to be used a lot and is close to the house a silenced model may reduce the stress both on you and any neighbours. However, an electric start, silenced generator is likely to cost twice as much as an open frame model with the same power.

Size

I was advised to get a much larger generator than I thought I needed. This has been good advice.

The size of most generators is expressed as VoltAmps (VA) or Watts (W). When a generator is powering a “resistive load”, such as a light bulb, then the two measures are the same but when it is powering “inductive loads”, such as electric motors or battery chargers, the wattage being produced is actually lower by a figure called the power factor. The power factor varies, depending upon the item being considered but can be as low as 0.6. My generator is rated at 5.32 kVA. If my battery chargers were rated at 0.6 then the actual available wattage would be just over 3 kW. I cannot find any published information about the power factor of my battery chargers. To put it another way, my battery chargers can deliver 50 A at 24 V (1200 W) to the batteries. However, if the power factor of the chargers is 0.6 then the demand on the generator is $1200/0.6$ or 2000 W. If we now take into account the fact that the chargers are 85% efficient, then to deliver this 1200 W to the batteries makes a demand of more than

2350 W on the generator. This could seriously challenge or even damage a small generator of, say, 2.5 kVA.

We are dependent upon our generator and so having a unit that easily copes with any individual item is a blessing. If we choose to switch the generator to the household we have sufficient power most of the time to run all the household appliances and charge the batteries at the same time. Generators are somewhat like cars; if you drive them too slowly you get fewer miles per gallon. In the case of the generator, I feel it is always best to run the optimum number of appliances – such as charging the batteries, running the household and using the irrigation pump. To use the generator for the irrigation pump alone would be much less efficient.

Fuel

The choice is normally put between petrol and diesel but how about a gas conversion? When we talked of using a gas generator, most of the British ex-pats I talked to were sceptical. Using the web, I could not find any Spanish company supplying such generators. Consequently, we brought a converted model in UK and shipped it with some furniture. When the local gas fitters saw it they took it in their stride. Indeed, since getting to know our neighbours, I have found several who also use gas as their main fuel. This can either be butane as in the 12Kg bottles or, as in our case, the 35kg bottles of propane. The joy is in not having to refuel. The generator is permanently connected to the supply. We have a bank of ten bottles (these also supply hot water, central heating and cooking) and the gas supply truck happily braves the entrance track to deliver them. It is said that a 5kVA generator uses 1.2 kg an hour on full load. This generates about 1 kWh of power into the system. Is it cheaper than petrol or diesel? Having used all types of fuel, gas is certainly the most convenient. In the event of a gas shortage it can also run on petrol. One neighbour who uses both butane and petrol for his generator says that butane works out much cheaper.

Last winter our Honda powered gas generator was used six or more hours a day. Regular servicing is an imperative. Oil and air filter servicing is required much more often than I would have expected. The spark plug needs cleaning every six weeks or so and the dusty atmosphere requires cleaning the air filter with similar frequency.

Location

If you have a small generator that can be moved around, location is not really an issue, but with a big generator connected to a static gas supply it can be very important. We had originally planned that the generator would be put in the washing room (with the exhaust routed outside) and the gas bottles would be on the outside wall of the building. However, the gas inspection engineer said this was not acceptable and that the generator had to be 5 metres from the bottles. A suitable arrangement was made with an outhouse containing the generator and, after the system was changed, the other components of the solar system. All was well during the winter. However, in the summer a problem arose. The main use of the generator, in summer, is to run the air conditioning, so it is used when it is hottest, with outside temperatures regularly above 30°C. The heat from the generator caused the temperature in the room to rise dramatically with problems for the inverters. We have had to move the generator outside for summer. With forethought this problem could have been avoided.

Generators and Appliances

To protect against power supply fluctuations I use uninterruptible power supply (UPS) units on all vulnerable equipment, such as computers and entertainment systems. These protect against power surges but also keep equipment running when switching from generator to inverter supply. Ideally, we would have an “automatic transition switch” which would keep the whole mains supply working for the brief period when switching between generator and inverter. Units, which combine battery chargers and inverters usually have such switches built in.

Voltage Creep.

The voltage generated by a generator is determined by the speed of the engine. The faster the engine goes the higher the voltage produced. Some generators have electronic regulators that keep their voltage within a specific range. More common, however, is a regulator on the engine, which allows the engine to increase in speed when there is a high demand. It does however assume that the engine has been adjusted to the correct voltage. We just assumed that the voltage being output by our generator was electronically regulated, a big mistake. Over time the speed of the engine gradually increased to a point where serious damage was caused to a range of equipment. Protective devices could not prevent this (indeed they were themselves damaged) because such devices protect against power surges and not against high voltages.

Part of the problem is that most generators show substantial voltage drops when a heavy load is applied. Thus, when charging a battery the output voltage might be 225-volts. However, when the battery is fully charged the load drops and the voltage increases. The generator might now be supplying 300-volts to appliances which take little current. Among the devices damaged were computer power units and the electronics in the water heater.

Since that time I have checked a number of generators and found that many are generating unacceptably high voltages. When servicing a generator it is advisable to check the voltage on and off load. It was these experiences that lead us to adopt the battery support mode of operation because our battery chargers have a wide range of acceptable voltages. It is a less efficient use of the generator but with our expanded system the generator plays a smaller part and the gain in security feels worthwhile.

Batteries

Battery Size - Voltage

The basic question is whether to use a 12 or 24-volt battery. Most domestic systems use 12 volts because it is not envisaged that very high currents would be drawn. 12-volt systems seem to be used with inverters up to 1.5 kW. A washing machine, when connected to the inverter, could draw over 120 amps from a 24-volt supply when heating water; on a 12-volt system that would be 250 amps and require a substantial size battery and cables of twice the diameter.

Battery Size - Capacity

The second issue about battery size concerns the capacity of the battery - that is, how much power do you want to draw, for how long, between charges?

In solar systems without independent chargers the size of the battery is calculated on the basis of the power used and the amount of charging from the solar panels. In a typical weekend *cortijo* the power is used for two days and then the panels have five days to recover the charge.

If the power is used over seven days, the battery must have sufficient capacity to cover the total amount of daily energy. Additionally there needs to be capacity for days when there is little solar power. As shown in Figure 2, poor weather comes in blocks so - how many days with little charge do you need to cover? Additionally, when you do start charging, the panels must be able to cover the daily needs and still have sufficient capacity to charge the batteries.

In systems with a backup charging system the calculations are easier. I want our batteries to be able to supply one complete day and if there is not solar power to cover this I will use the generator.

Of course if you are using the inverter to supply large loads like washing machines then you need a much larger battery. The higher the current being drawn from a battery, the lower the effective capacity.

Battery Configuration

Unless your solar system is very small your choice of battery type will be between leisure batteries and deep cycle batteries. Leisure batteries usually are 12-volt units and deep cycle batteries are usually 2-volt units.

Normally a group of leisure batteries are connected together in pairs. Two batteries are connected in series to create 24-volts and then additional pairs are connected in parallel to increase the capacity. If you are using 240 ah units then the first pair gives a battery of 240 ah, the second adds another 240 ah and you can add additional pairs up to the required capacity. E.g. Eight batteries will provide 960 ah. With this configuration if a battery fails then removing the pair allows the system to continue functioning.

Commonly, when installing deep cycle batteries the approach is to install a set of 2-volt units of the required capacity. For instance to get a 960ah system you would install 12, 2-volt 960ah units in series. These units tend to be reliable but if one unit fails the complete battery fails because the circuit is broken.

Being concerned with security when we updated our system we chose 460ah deep cycle units each of which configured into 6-volt groups. In effect this gave us two 460ah sets. Indeed when our new batteries arrived one cell was faulty and half of the system did not function. We were able to function on the 460ah system while we awaited a replacement under guarantee.

Checking For a Faulty Cell.

The only really efficient way to know how a battery is performing is to check the specific gravity of the cells using a hydrometer. However, checking the voltages can give a good indication that something is amiss.

Normally all the batteries will register similar voltages. However if there is a faulty cell this will not be the case. Check the battery voltages when they are fully charged and also when partially discharged. When fully charged a 12-volt battery should read about 12.7-volts. After a period of discharge they should again register similar voltages (e.g. 12.3 volts) if they do not there could be problems. On a bank of six batteries I found two pairs reading 12.3 –volts. In the other pair, one battery read 13-volts and the other 11-volts. Checking the specific gravity showed that one cell in the battery reading 11-volts was completely defunct. It would charge up but then completely discharge on load. Once discharged that pair was effectively open circuit.

Battery Connections

How batteries are connected can affect their life span.

If a group of batteries are connected together then the lengths of all parallel cables must be the same. This means that the cables connecting each battery to the other must be the same length as must be the cables connecting the positive and negative terminals to the output.

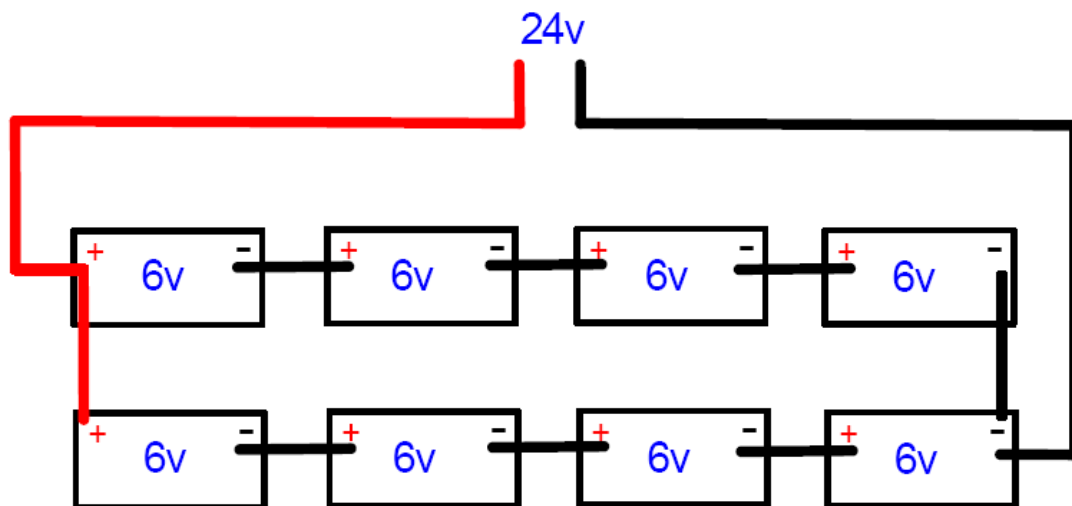

It is common practice to wire batteries with some variation of the following.

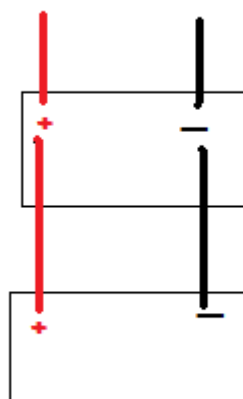

What is apparent here is that the first unit in the battery is going to be required to do more work than the second, comparatively shortening its life. The correct wiring would be to connect the load to the negative of the second battery, ensuring the both sets of cables are the same length.

Battery Charging

The batteries are a core component of a solar system and over its lifetime they can turn out to be the most expensive part. In a well-used system they may only last three years. Apart from simple use, the main reason why the life of a battery is foreshortened is because it has not been charged properly. There are recommended procedures for charging batteries and these require an “intelligent” charger.

Note: There is an excellent paper (albeit commercial) on batteries and their charging at <http://www.victronenergy.com/upload/documents/Book-EN-EnergyUnlimited.pdf>

When a battery discharges, there are internal chemical changes. When it is recharged the changes are reversed. If the battery is not charged fully, then the chemical reactions are not completed and gradually the capacity of the battery is reduced. Thus a 200 Ah battery starts to behave like a 100 Ah battery because it has not been charged properly. If it is overcharged then a loss of electrolyte can occur.

The key parts of the charging recommendations are the first two stages of a four-part process. It is usually recommended that, in the first part of the charging process, a battery is charged at about 10% of its capacity. Thus for a 500 Ah battery the initial charge current would be 50 amps. As the battery becomes charged the voltage increases to an optimum level (usually referred to as the absorption voltage), and at this point the charging current must be reduced. The absorption voltage depends upon the type of battery, e.g. 28.6 volts for a 24-volt lead acid battery. Once the absorption voltage is reached the charging voltage is held constant and the current reduced. As the charge is consolidated, less and less current is required to hold the voltage. At this point the charge is completed, though a third stage (float) at a lower voltage can finish the process.

Percentage of Charge	12 Volt Battery Voltage	24 Volt Battery Voltage	Specific Gravity
100	12.70	25.40	1.265
95	12.64	25.25	1.257
90	12.58	25.16	1.249
85	12.52	25.04	1.241
80	12.46	24.92	1.233
75	12.40	24.80	1.225
70	12.36	24.72	1.218
65	12.32	24.64	1.211
60	12.28	24.56	1.204
55	12.24	24.48	1.197
50	12.20	24.40	1.190
45	12.16	24.32	1.183
40	12.12	24.24	1.176
35	12.08	24.16	1.169
30	12.04	24.08	1.162
25	12.00	24.00	1.155
20	11.98	23.96	1.148
15	11.96	23.92	1.141
10	11.94	23.88	1.134
5	11.92	23.84	1.127
Discharged	11.90	23.80	1.120

When the charged battery is disconnected from a load the voltage should be 12.7 volts, or 25.4 volts for a 24-volt battery. When the battery registers 24.4 (12.2) volts it is 50% discharged. It is fully discharged by the time it reaches 23.8 (11.9) volts. If

there is a load on the battery then voltage displayed will be lower. Most inverters have a cut out that prevents the system working when the battery voltage is low because continuing to use a battery in a discharged state can damage it.

Apart from its capacity a number of factors determine how long a battery will take to discharge. First is the state of the battery; if the charging process is unable to change the internal chemistry then the battery may appear charged according to its voltage but not be charged in practice. In that case the use of a hydrometer to determine the specific gravity of the electrolyte will be a more accurate indication. A second influence is temperature; the hotter the environment the lower the battery capacity. Finally, the nature of the load; if a high current is drawn from the battery then it will discharge more quickly than if a low current is taken.

There are advantages in keeping a battery well charged – apart from the fact that when it is well charged it takes less time to recharge it, batteries that are kept well charged tend to last longer. Further more, inverters tend to be more efficient when running with a fully charged battery. I was told that the inverter could be 95% efficient when the battery is fully charged while at 80% charge it will only be 85% efficient.

Equalisation Charging

Over time the voltages of the different units in the battery may become unbalanced. To correct this some manufacturers recommend equalisation charging. This involves charging the battery to a much higher level – in our case 31.5-volts – for a period of time. This process should bring all the batteries to a similar state of charge.

Not all battery chargers can undertake an equalisation charge.

Battery Maintenance.

Most batteries used on solar systems are lead acid batteries, which are filled with a mixture of acid and water (electrolyte). As these batteries are used the water tends to evaporate reducing the effectiveness of the battery. If the cell dries up it may cease to function altogether.

The main check to make is thus to undo the top of each cell and check the level of the liquid. Normally this should be around 40mm from the top of the lead plates. If it has fallen substantially then the cell should be topped up with distilled water.

Our deep cycle batteries come with a 7-year warrantee but this is dependent on the electrolyte being regularly checked. The warrantee also requires that the specific gravity of the cells be checked every six months.

Gel batteries, which are sealed, cannot be checked and maintained.

Battery Management

But how far should you allow a battery to be discharged before recharging? There seems little agreement about this. I asked quite a lot of people and tended to get vague responses about what they did or what they would recommend. Many manufacturers say that the life of their batteries is, for instance, 1000 full charge and discharge cycles, which implies that the battery could be fully discharged and then recharged 1000 times. Another article says letting the batteries fall below 50% tends to reduce their life.

Part of the difficulty in general charge management is actually measuring the state of charge. Many solar regulators and inverters do not provide basic information; they simply use lights or a dial to indicate the state of the batteries. You have to trust that the information is correct for the battery type. It can, as I suggest above, be misleading and when you think you have a fully charged battery it is in fact partially discharged. I have two solar regulators, one of which only has indicator lights; I have installed a separate meter between that regulator and the batteries

My approach to battery charging is as follows. Once the sun sets I check the battery voltages. If they are reading below 25 volts I put on the generator for a time. In the morning I check that they are reading above 24 volts, if they are not I put on the generator. At least once a month I fully charge the batteries.

In theory, these readings should be taken with no load on the batteries, which is impractical. If the fridge/freezer is actively cooling and the computer is on then the measured voltage can be as much as 1 volt lower than the off load reading. If the panels are charging it can be over 1 volt higher. These factors need to be taken into account.

However, it is important not to be misled by the voltages. As a battery becomes discharged its capacity tends to be reduced. One sign of this is that when a load is placed on the battery the voltage drop is much greater than normal. I had the experience after a period of running on the margin where the inverter suddenly cut out (giving a low battery warning) even though the voltage was still 24 volts. In fact the batteries had become discharged and when a sudden load was placed upon them the voltage dropped. Then with the load disconnected the voltage returned to 24 volts. Properly recharging the batteries prevented this from happening.

Solar Regulators.

Solar regulators (or chargers) are similar to battery chargers except they take their power from solar panels rather than generators. Most are three or four stage chargers that will have settings for different types of battery. Some will display detailed information about the charging process others will just have a few lights to indicate what is happening.

If your model of charger only has lights to display its status it may be worth investing in a measuring device. Most companies that make chargers (both solar and battery) also supply these measuring devices but they can be very expensive. I have installed a device called "Watts-Up" (<http://www.rc-cars-planes.com/>) on the charger that only has lights and this gives me comprehensive information about the functioning of that charger such as voltage, amperage, current power (watts) and total power provided. This little device costs a fraction of that charged by the main charger makers.

How do solar regulators work? Basically, the solar panels provide power to the solar regulator, which uses that power to charge the batteries. In the traditional type of regulator the voltage supplied by the panels is tied to the voltage of the battery. Given that the amount of current that can be supplied is limited this means that when the battery is low the panels are not necessarily operating most efficiently.

Recently a new type of charger has appeared on the market – usually referred to as the MPPT charger. These chargers are able to monitor the performance of the panels to allow them to work at their maximum efficiency. It is claimed that these chargers can achieve up to 30% more power from a set of panels than the traditional type. However, this improved efficiency is mainly seen when the panels are at lower temperatures. Thus they tend to improve performance in the winter more than in the summer.

Some of the MPPT chargers also allow panels to be connected to form higher voltage arrays. We have a 72-volt panel array that is stepped down to 24-volt by the charger. The advantage being that, because the current is lower, the cables can be of smaller diameter.

Inverters

Inverters take a DC supply and convert it into an AC supply at (in Europe) 220 volts and with a frequency of 50 cycles. The electronics, which make this conversion can be more or less sophisticated with the least expensive models providing only a crude approximation (square wave) to a true sine wave. The best models provide a supply that is as good, if not better, than the mains supply.

Only modified sine wave and pure sine wave inverters are suitable for solar installations. Square wave models will not run most domestic appliances. Pure sine wave models will run any appliance that will run on normal mains while modified sine wave models will run most types of appliances. Generally, modified sine wave models cost substantially less than the equivalently powered sine wave model.

Modified sine wave models are said to run 85% of all appliances but not voltage-sensitive white goods (see the section on appliances). I have recently installed a 600 watt modified sine wave inverter and found that it will run most appliances like computers, televisions and also lighting circuits. However, the induction motors that drive most fans do not like being powered by this inverter. Although the fans work they emit an unpleasant humming sound; this applies to ceiling fans and also extractor fans in the cooker hood and the gas water heater.

Inverters come in various sizes. The smallest will supply 150 watts and they can range up to 6 kW in output. Those that run from a 12-volt DC supply are rarely bigger than 1500 watt, larger units tend to be 24 or 48 volt.

Apart from the power it can provide, there are two issues when considering an inverter. Firstly, its capacity to deal with “surges” in power. Many appliances, like fridges and cathode ray tube televisions, have a power surge when they start. This surge is far greater than their power demands after they have started. If the surge is greater than the inverter’s rating the system will shut down. Most inverters can accept surges greater than their rating but not all.

Inverters use power when running, even with small loads. The amount of power used (called the quiescent, or standby, current) can be quite high with some models. For instance our Solener 3000-watt inverter appears to use about 22 watts, which means that if the only appliance running in the house is a 2-watt nightlight, the inverter uses 24 watts. I shall consider this issue in the following section.

Some models of inverter can be connected to increase the power supply. For instance rather than buying a single 3000-watt inverter you might buy two 1500-watt models. Thus you still have a functioning system if one should fail.

Battery Chargers.

The most important feature when buying a battery charger is that it has the ability undertake three stage charging.

A second feature is the charge capacity. Ideally the battery charger should be able to charge at 10% of the battery capacity. So a 500ah battery would demand a 50-amp battery charger. This latter feature is desirable but not absolutely necessary. Currently I have a 50-amp charger working with a 960ah battery. This functions well because most of the charge comes from the panels and the generator is only for support and backup purposes. If I were still taking most of my power from the generator then I would need to increase the size of my charger.

I actually have two chargers connected in parallel so if one should fail there is always some charging capacity. However, if I need to increase my charge capacity there is nothing to stop me adding another charger. Each charger is independently switched so, if I am running the household from the generator I can determine how much of the available power is used for charging batteries and how much is taken by the house.

Most chargers allow you to select a charge method for different types of batteries; some let you set specific voltages for each stage in the charging process. For instance the bulk stage in lead acid batteries is normally terminated at 28.6 volts. My batteries recommend 29.6 volts, which is higher than the standard setting available on my chargers. Models also differ as to how they handle the float stage; some have a set period that can be selected (e.g. 2 hours) others measure the current flow into the batteries and terminate the stage when the current falls to a minimum.

If your batteries are likely to require equalisation charging then a charger capable of supplying the required voltage is needed. However, in our case the recommended approach is, in the morning, to use the charger to charge the batteries to their maximum. Then as the solar energy becomes available the solar charger can undertake the equalisation charge.

Combined Battery Chargers and Inverters

There are a number of products that combine a battery charger and an inverter into the same unit. Originally we had such a unit, made by Victron, which contained a 70-amp charger combined with a 3000-watt inverter. This is less expensive than buying the separate units but, from my experience, I would never purchase them in combination again.

The two component parts of the unit, the battery charger and the inverter, work in combination. When the generator is not working the inverter provides power for the household from the batteries. When the generator is switched on the inverter is switched off. The generator supply is divided between the battery charger and the household.

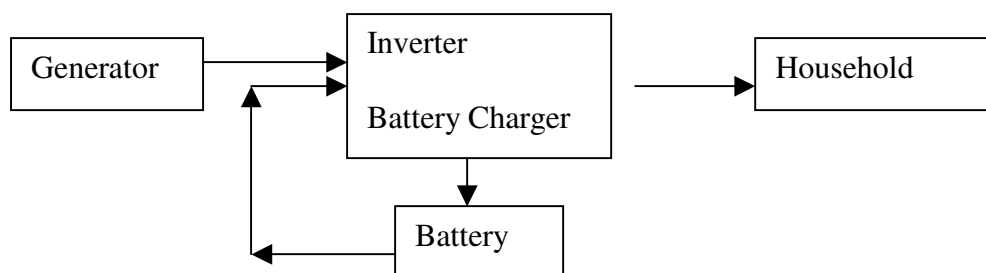

My experience suggests there are several potential problems with these units.

In general, because they are designed for nautical use, they offer many different set-up options and neither of the two engineers that I have observed installing them seemed fully familiar with these options.

The unit applies a limit to the power that it can supply – in my case 3000 watts – but this limit includes not just the household appliances but also the power diverted to charge the batteries. In the Victron unit this was a major problem. We found ourselves wanting use the generator when we had heavy household loads but because much of the power was diverted to charge the batteries the unit would overload. You could not reduce the power being diverted to the batteries without removing the case and resetting various dipswitches.

You cannot charge the batteries without switching the generator supply to the house. Having experienced the damage a faulty generator can do to domestic appliances I am wary of connecting the generator directly to the household supply.

Finally, as both battery charger and inverter in the same unit a failure in one section means the whole unit has to be replaced. In our case, the battery charger developed a fault. However, the item was covered by a return to base warranty – and the base was in Holland. Neither the manufacturers nor the installers were prepared to offer a replacement unit – because, as the manufacturers explained, it would take less than a week from the time it was removed from my system till it was returned! Sceptical of their timetable I resisted, mainly because this would have meant our having to rely solely on the generator for power. Eventually Remote Energy agreed to purchase the unit back – but only after it was repaired under warranty. We therefore had to buy a new unit and wait for the other to be returned before being reimbursed. I bought an independent battery charger and inverter. It was about 3 months before Victron had the original unit back in Spain in working order!

Will your appliances work with your system?

If the generator/inverter output is a pure sine wave then almost all household appliances can be connected directly. Most will also work with modified sine wave machines. Some will not work with generators.

In talking to people using solar systems, the appliance that is most likely to cause problems is the washing machine. This was the only appliance that would not work from our generator. It would not even switch on! It had to be connected to an inverter. A washing machine technician has told me that none of the modern efficiency rated machines (i.e. A rated and better) will work from a generator.

Another appliance that may cause problems is the gas combi-boiler that provides hot water and controls the central heating. These are becoming increasingly sophisticated and the internal electronics are vulnerable to damage by voltage fluctuations. A neighbour who is building a cortijo near us installed a model made by Ferroli that has never worked. The technician from Ferroli has now stated that boiler must be changed for another make because their boilers will not work with solar energy. Our combi-boiler made by Baisi does work but the technician has told us they have had many problems with running these from inverters and generators.

You can get considerable voltage fluctuations even with a powerful generator. When our fridge starts up, the generator-supplied voltage in the system drops from 220 volts to about 200 volts – our 3000 W inverter, however, only drops from 229 to 228 volts. Washing machines, dishwashers and microwaves are particularly sensitive to voltage fluctuations. Because they use sophisticated electronics, the spin cycle of washing machines can be very sensitive. If I put on too many appliances then the spin cycle will not work and I know of one couple whose washing machine will wash from the generator but not spin.

One item that can cause particular problems is the microwave oven. I had assumed that our 800-watt microwave would be using 800 watts. In fact when it's running on full power it is taking 1500 watts and drawing 50 amps from the batteries. I had also assumed that when set to the defrost setting of 160 W that it would take about a fifth of the power. However, this turned out not to be true. When on its low power setting the microwave actually takes the same amount of current but in bursts. So instead of taking a constant current of 50amps, for say, 10 minutes, it takes 50 amps for 5 seconds and then takes very little for 25 seconds (the times are only for illustration). Over the course of the ten-minute cycle it does use less total power but when using power it takes exactly the same amount of current as on full power. When running from the generator, this pulsating power causes havoc with the washing machine, which simply won't spin when the microwave is on defrost!

On those occasions when I run the household from the generator, I can vary the amount of power being used by the battery chargers. I have learnt the optimum combination of appliances that can work together. For instance, I can run the household, the irrigation pump and two battery chargers together, but only the household, one battery charger and the washing machine.

Another point worth considering is the size of the inverter. Spanish installers seem to install inverters with little power – often the smallest pure sine wave they can find. There seems to be a philosophy in this – “if you live in the campo you cannot have the same facilities that you have in the town” one said to me. “Why not?” was my silent response, not wanting to be given another lecture. And why, if you install a 600-watt inverter, install an expensive pure sine wave model when most of the appliances you run will work on a modified sine wave? It seems to me that a lot of appliances – hair dryers, microwaves for defrosting, bread makers etc – use between 600 W and 1000 W for short periods of time. Switching on an expensive generator to run a hair dryer for ten minutes is simply not cost-effective and is also very inconvenient.

Many appliances, such as refrigerators and televisions, have a very high start up current. Some appliances will not work, though they should, because the start up current of the appliance exceeds the power of the inverter.

Running Domestic Appliances Efficiently

It was inevitable that once I started to write this article I would begin examining my own system. When I started writing, we were using in excess of 5 kWh (excluding items which were always run from the generator washing machine, microwave, irrigation pump) a day but now we are using around 3 kWh including the power used by the larger items. This has led to a dramatic reduction in the amount of gas used for the generator.

Below I give various figures for the power used by appliances. These figures are based on actual observations of my system. There are now a range of energy

consumption meters available which makes such measurements much easier. However, when buying energy consumption meters ensure that they have backup batteries otherwise when the appliance switches off you lose your readings.

Selecting Energy Efficient Items

Lights

Probably the greatest single change you can make to improve energy consumption is to use energy-saving light bulbs. Though they take a little time to reach full brightness, once they do, they can give the same brightness as their equivalent standard bulb for small proportion of the power consumption. Be aware, however, that halogen bulbs are not energy efficient. A 60 W halogen lamp may be small but it still uses 60 watts and a 7 W energy-efficient bulb could produce the same light. Fluorescent tubes are also to be avoided if possible. They have a high start-up current and the same amount of light can be provided and spread by using several energy-efficient bulbs, for much less power.

Domestic Goods

The energy efficiency of white goods such as washing machines and refrigerators is increasing all the time. However, one needs to be aware that this may come with sophisticated electronics, which will only work with a pure sine wave output. Our Balay dishwasher and washing machine seem to work well. Our Siemens fridge/freezer seems less efficient and uses considerably more power than I would have expected.

Most of the power used by washing machines and dishwashers is used to heat water. The amount of power used is much lower in the summer than in the winter because the summer water from the supply is warm. In April our washing machine was consuming 760 Wh when washing at 40 °C. Most of this is used when heating water, using 3 kW – fortunately for only a short period of time. Our Balay machine can wash cold, which works well with lightly soiled articles. On its lightest wash it only consumes 80 Wh. This suggests that for cold washes, it is more efficient to run the machine from the inverter, particularly when there is sufficient power being delivered from the panels. The reason is that the generator is not being used to its optimum capacity because the washing machine is reluctant to share the system, when powered by the generator, with other appliances – such as a battery charger and microwave. It appears to me that, when the panels are delivering power, the inverter takes priority, so that power goes straight to the appliances and only that not used is delivered to the battery charger.

Televisions vary widely in consumption but the larger the screen the greater the consumption. The older cathode-ray types also tend to use more power than the LCD ones.

One Pot (slow) Cookers

One item that has become an essential part of our kitchen has been the slow cooker. Its appeal is its consumption. It takes less than 500Wh to roast a chicken and never takes more than 200 watts. It's at its best with slow cooked meats and stews.

We often use it in conjunction with a small electric oven. This takes more power (and is usually run from the generator) but it is only used for short periods of time.

I strongly suspect but cannot prove that cooking a meal with this combination is more efficient than using gas.

Computers

When I compared the power consumption of my small desktop computer (with its screen off) with my portable (both running the weather station) I got a surprise. The desktop was using 140 W compared to 40 W for the portable. Given that I was running this system 24-hours a day, the saving achieved by using the portable to collect data was considerable. It is also worth being aware that the battery chargers used with portable computers use power even when the computer is switched off. We have two portable computers, on one the battery charger consumes 20 watts even when the computer is switched off. On the same computer the other charger only uses 6 watts.

Appliances on Stand-by

Until recently many household appliances were designed to be on “stand-by” so that they were never switched off. Perhaps the most notorious of these is the “Sky box” which is said to cost £26 a year just to be connected to the wall. Just how significant this is can be seen with our Skybox and television. When on stand-by they consume 13 watts; when running, 20 watts. Thus if on for two hours a day (about our maximum viewing time) they consume 40 Wh; left on standby for the remaining 22 hours they would consume an additional 286 Wh.

Switching stand-by items off can be problematic. We certainly have to wait for the Sky box to find the signal and, very occasionally, we have to reset the frequencies. The biggest problem is with the DVD recorder that takes ages to set up and causes havoc in the system. Fortunately, it is rarely used.

Some items may be drawing stand-by power and you may not even be aware of them. When I first started monitoring power consumption I found a big difference between the consumption of individual items and the total. At first I thought it was an error but eventually discovered it was due to ceiling fans. We have three ceiling fans, which are controlled by infrared handsets. These were not in use, but the light switches were on – amazingly they were taking 50 W between them while doing nothing – this 1200Wh over a 24-hour period accounted for the difference. I now look askance at anything with an infrared control. Fortunately, the air conditioning unit, which cannot be isolated and uses an infrared control, does not use power when not in operation. On the rare occasions when this is used, we run the generator.

Using Timers to cut Consumption

Some items have a quasi-stand-by function. For instance, I have a weather station, which regularly exchanges files with other Internet based stations. Thus I had my Internet connection on permanently, using 15 watts, or 360Wh a day. I then realised that I only needed a connection for 15 minutes every three hours. So I put a timer on the modems and changed the weather station settings to exchange files during the period when the timer had opened the Internet connection.

While this approach solved some problems it still left the portable computer running 24/7. I eventually solved this problem by using a small utility programme. This programme can automatically put a computer in hibernation and then wake it up again. When a computer goes into hibernation all the running programmes are saved to disk and the computer is effectively turned off. My desktop takes less than 1W when in hibernation. When it “wakes up” everything is restored and the computer runs as it had beforehand. So now my computer remains in “hibernation” most of the

time. It “wakes up” just before the Internet connection is restored and continues “awake” until all the files have been exchanged, and then goes back into hibernation. It goes through this sequence eight times a day. If I wish to use it I manually wake it up and then put it into hibernation when finished.

Eventually, I even improved on this arrangement by using a surge suppression device that only switches on peripherals when the computer is running. When the computer is hibernating all the Internet connections are switched off. When it wakes up, power is supplied to all the peripherals, which then connect.

Our electric fridge-freezer is a problem. We prefer it to the gas model. It is supposed to be economic (rated at 960 Wh a day) but in practice it uses 1500 Wh – more than three times the available power delivered by our original panels in mid winter. The problem is that it continuously monitors the temperatures in the fridge and freezer and starts their cooling systems when the temperatures rise. We have experimented with putting it on a timer that switches on every two hours for 30 minutes. Obviously, you get some degree of temperature fluctuations. I have placed a temperature transmitter in the freezer and find that with this regime there is a temperature fluctuation between -14 and -18 °C whereas with the system full on there is little or no fluctuation. Using a timer, the power saving is dramatic, using only 670Wh over a 24-hour period. However, if you take this route you should be aware of the danger of the fridge getting too warm.

If you really want create an efficient fridge you can do this by converting a chest freezer. There are several articles on the Internet describing ways this can be done. In essence you install a thermostat (set to say 5 degrees) in the chest and use this to switch the freezer on an off. This can easily use less than 100 watts a day. The reason is that when you open a normal fridge the cold air “falls” out because it is heavier than the surrounding air. With a chest freezer the air stays in place. It may not be so convenient but it is certainly more efficient.

http://www.mtbest.net/chest_fridge.pdf

The Inverter

We have a 3000-watt inverter, which was installed because the system was designed to run all appliances via the inverter. Like most inverters it uses a standby current. It does not matter how much power is being used; the inverter will take at least 22 watts. Thus during the course of a day it uses 500Wh. It can be set so that it switches off if no power is being used. However, this leads to some problems. A gas heater supplies our hot water. This uses a small amount of mains electricity to detect if a tap has been switched on and then to ignite the flame. If the inverter is set to a level, which is high enough to detect the opening of a tap, it uses 22 watts. Similarly, if no other power is being used, the inverter will take 22 watts to charge a mobile phone.

If it's set lower, then it does not detect the tap. Other items can also show strange behaviour. Fluorescent lights will flash on and off but not start. Also appliances, which have periods of inactivity, can blink. Both the washing machine and the bread maker have periods when they are resting and at these times the lights flash on and off. There is a simple solution – just turn on a small light. This will be enough to keep the inverter on for periods when the appliances are resting.

These high standby currents are a characteristic of pure sine wave inverters. My solution to this was to add a modified sine wave inverter to my system and then create a separate electric circuit that runs all the low power items with minimum overhead, allowing the higher power inverter to switch off for long periods. When the main

inverter is switched off, either because it is in stand-by or because the generator is supplying the house, the small inverter will continue to supply the always-on items with minimum overhead. Fortunately the items which I wanted to run from this supply – computer, internet connection, night-light – were all mounted along the same outside wall, and the system was easy to install.

Conclusions

How much should you invest in Solar? Environmental issues apart, this comes down to the balance of costs and benefits. And this is often expressed in payback time – how long would it be before you start making a profit on your investment? I have done some calculations based on our electricity bills in both Spain and Britain. In Spain the total cost of electricity (in 2005) was €0.14 per kWh whilst in Britain it worked out as €0.35 per kWh (exchange rate 1.5 euros to the pound). Our average daily consumption was also high, being about 8 kWh in Spain (in spring) and 23 kWh in Britain (in winter). Both houses were heated by electricity. Clearly unless there are subsidies or rising prices the investment would take a long time to repay.

When living, off-grid, in the country the issues are more complicated because the basic choice is between having and not having electricity. So the question is really, how much power do you want and at what price.

12 volt Systems

In the earlier part of this article I expressed an admiration for the various 12-volt systems. We know several people living in the country with such systems. One only uses direct current (taken directly from the batteries); the other uses a low power alternating current taken from a small modified sine wave inverter. Take the example of the latter system. This system involves a single solar panel, a regulator, batteries and a small generator used for when the batteries are not fully charged. They are able to run lights and entertainment systems. The generator is very small, just sufficient to cover the power that the system can supply. Thus it's extremely cheap to run. They have a larger generator for washing machines, power tools etc.

In an earlier version of this article I made some cost calculations based upon actual prices. However, with inflation and changing exchange rates these were redundant within a year. In this paper I only give a rough guide to the costs of the system. A 12-volt system, as described above, could be installed for between 1500 and 2000 euros.

A Basic 24-volt System

However, we could not live with such constraints. To some extent our own system is almost the opposite because, from the outset, we have wanted to live in the country in Spain in a similar way to which we lived in the country in Britain. In theory we wanted to run appliances like toaster, iron, vacuum cleaner, bread maker, hairdryer, washing machine, dishwasher, fridge freezer and computers plus ceiling fans and lighting, as well as power tools, cement mixers and the irrigation pump directly from the inverter (not all at the same time), with minimal use of the generator. At the very least this requires a 24-volt system.

Our initial system comprised 6 panels providing 510 watts, solar regulator, battery chargers, 3000-watt inverter and a 560ah battery. We have made substantial improvements in energy efficiency but in January 2007, our average daily power input (supplied by panels and generator) was 7 kWh per day. The generator supplied 75% of this. This power covered the average daily consumption of 4kWh; the

remaining 3kWh was lost in system inefficiencies. In the summer our average daily power consumption is lower about 3kWh of which 25% was supplied by the generator. The difference between summer and winter was not larger because the only real difference between summer and winter consumption is that in winter we are running the central heating pump and use more (low energy) lighting in summer we use ceiling fans.

This system needed management. During the winter the ongoing needs for power (lighting, fridge freezer etc) were supplied directly from the batteries via the inverter. Given there was insufficient solar energy the generator was being used to maintain the batteries. Whenever heavier loads were connected (washing machine, irrigation pump) then the generator was used to supply these. In summer in order to maximise the solar power the panels were moved twice a day increasing their supply by 40%. This was sufficient to maintain the batteries but the generator was required for heavier loads.

This type of system could be installed for between 9000 and 12000 euros.

An Enhanced 24-volt System

In Spring 2008 we enhanced our system. We added three more panels, which brought the potential supply to over 1000 watts. We changed the solar controllers to the MPPT type and eventually added a 960ah deep cycle battery. We also began to run the system in battery support mode using the generator only to charge the batteries. The effect has been dramatic. Between April and the middle of September our average daily power input (panels and generator) was about 4.5kWh (consumption around 3 kWh) of which about 5% came from the generator. Indeed with the panels now able to generate over 5 kWh per day the use of the generator has hardly been necessary.

The excess power has led us to discontinue some of our power saving practices. At the moment the fridge/freezer is not on a timer and all the household power is run through the 3000-watt inverter. We have also reduced our consumption because I have replaced my desktop computer with a portable. On the other hand given that the power is available we have started using the dishwasher on its eco cycle.

As we have not been through a winter with this system we cannot tell how much gain we shall achieve throughout the year. However, one indicator of gain is the reduction of gas consumption. In both April 2007 and 2008 we started with a new set of 5, 35kg bottles of gas. In 2007 we made our 3rd refill at the beginning of October. This year (mid September) we are still on our original set of bottles. I am confident that they will last through till at least October. With refills now costing 230 Euros or more, the saving currently stands at 500 Euros over 5 months!

Could we reduce our consumption further?

When I started to write, the first version of the article, reducing our energy consumption was not something that I had really thought about. We had made our choices about our lifestyle and did not envisage that we could live more efficiently. In fact we have managed to keep our lifestyle while reducing consumption by about 60%. Could we do more? Obviously we could but at the moment we don't feel the need.

The whole process has made me conscious of the way energy is being wasted. We still have a small apartment in Britain. Its quite new, is all electric and supposed to be energy efficient. Yet in that apartment, in summer, we consumed more power before breakfast than in a whole day in our house in Spain, where we now live permanently. I would never have thought about these issues when I started to write this article.

How do we feel now?

Have we learnt to live with solar energy? When I finished the second version of the article I replied “Yes, but with a degree of ambivalence” to this question. The basic 24-volt system worked but we had to manage it and my wife did not feel confident that she could operate it over time. Now, I would give an unqualified yes. Our current system needs to be watched rather than managed.

Given the repeated problems and the subsequent anxieties, security of supply has been a big issue. Our supply seems secure in that most components are duplicated. It is in effect two separate solar systems working together. The only component that is not duplicated is the 3000-watt inverter but even for that there is a 600-watt backup.

When this system was planned I simply did not know enough to ask the right questions, and therefore we ordered a system which appeared good on paper but, even if it had worked, did not really fit our needs and would have been expensive to run. It seemed to us that living with solar energy was a precarious and worrying experience that was only possible if we restricted our outlook.

Indeed this was the view that was taken by many of our Spanish neighbours and the local electricians and solar installers that we have encountered. Their view is that solar energy is sufficient for a weekend cottage and no more. They were shocked at our original installation (far too complicated) and not surprised at our problems. There was a fair amount of “serves you right for not using a Spanish company” feeling about.

At that time I had not encountered a Spanish company that inspired confidence. However, over the last year two set of neighbours (non-Spanish) have had systems of similar capacity to ours installed, by a Spanish company and both are well satisfied with results and the price. Having said that the company is part of a European wide franchise.

To some extent we have now designed our own system and chosen our own priorities. The first of these has been security of supply, which makes the system more costly. The second has been to investigate our electricity use and try to find ways of eliminating unnecessary use, while maintaining our standard of living.